



# KleenScreen™ Revolver Range

The **KleenScreen™Revolver** has a unique backwashing system with all revolving components inside a stationary screen. The drive system has the backwashing nozzle passing across a sail, which creates a pressure differential, rotating the sail and nozzle.

This design is particularly effective in self-cleaning screens for relatively small flow rates.

## Benefits

### Energy Saving

With a small portion (2.5% - 8%) of pumped water backwashing and rotating the screen, it is continuously cleaned. This maintains the pumping efficiency of the system at optimum, thereby reducing power consumption.

### Repairs and Maintenance

The narrow screen slots (0.5mm wide) filter water entering system. This can significantly reduce the wear on pump and other system components.

### Labour Saving

By reducing major causes of water supply problems, ie screen blockage, loss of prime, and wear on pump the labour required to maintain the system is reduced significantly.

### Durable

Stainless steel and thermoplastic components ensure rugged construction and long operational life.

### Environmentally friendly

Satisfies Environmental Council requirements for screen hole size, and intake velocity.

*Self Cleaning Intake Screens to protect pumps and systems from organic and inorganic debris.*



**KS5**



**KS2.5 with standard  
wedge-wire**

# Components

Stainless Steel screen, end caps, sail, and frame provide strength and durability.

Thermoplastic bearing for reduced wear.

Internal baffle to evenly distribute flow over whole screen and maintain maximum intake velocity below 0.15m/sec.

Standard cage is wedge-wire mesh with a wire spacing of 0.5mm which dramatically reduces the amount of grit entering the intake.

Backwash inlet fitting 1/2" BSP thread

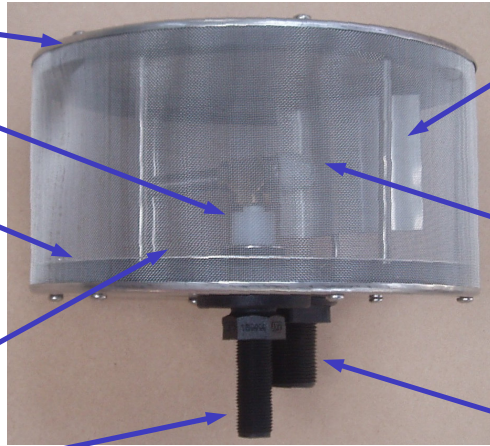

Fan nozzle directed nearly perpendicular to the screen provides efficient backwashing at low volume and pressure.

Convex Drive Sail creates a pressure differential either side of the sail as the backwash jet passes across the leading face. This pressure differential rotates the sail/nozzle assembly, (without the need for drive nozzles), using only 2.5-8% of the maximum flow at 30 metres pressure (45 psi)

Outlet fitting 1-1/2 - 4" BSP thread, 80-100 or 150mm Table E.

**KS2.5**

# Typical Installation

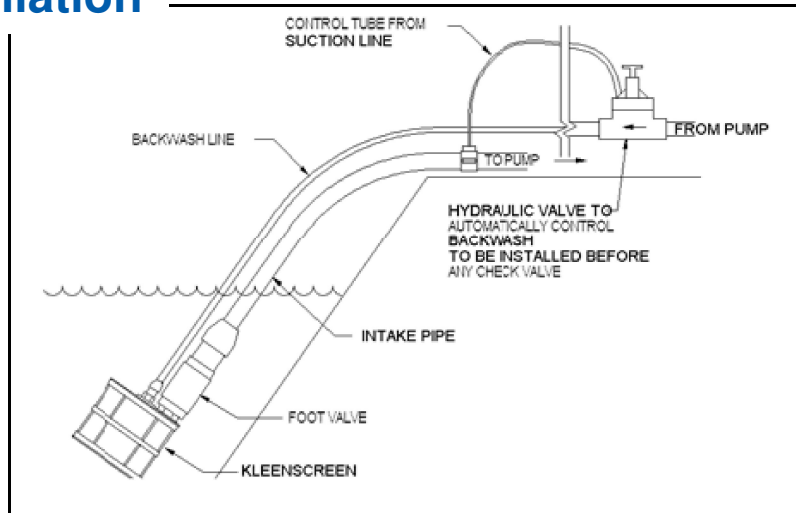

MODEL	Maximum Flow (Wedge-wire with 0.5mm wire spacing)				Outlet Pipe	Backwash Flow @ 30m head	Screen Diameter	Overall Length
	L/s	m <sup>3</sup> /hr	IGPM	USGPM				
<b>KS2.5</b>	2.5	9	33	40	1-1/2" Male BSP	0.2	250	130
<b>KS5</b>	5	18	66	79	2" Male BSP	0.2	250	215
<b>KS10</b>	10	36	132	158	4" Male BSP or 80-100 Flange	0.4	250	405
<b>KS15 0.9mm</b>	15	54	198	237	80-100 or 150 Table E Flange	0.4	470	250



**DAMA MANUFACTURING LIMITED**

46A Weaver St  
WHANGAREI, 0112  
NEW ZEALAND

Ph: +64 27 493 3183  
Fax: +64 9 437 3338  
info@kleenscreen.com

